

LBT-08420

8.4 inch Open Frame LED Monitor



Features and Options

- Compliant with RoHS, UL, CSA, TUV, FCC B, VCCI B, CE TCO 99, TUV Ergo, EPA Energy Star
- Perfect for kiosk, equipment and instrument drop-in designs
- Superior viewing angles, contrast ratio and brightness
- Robust ventilation structure
- Durable **Resistive** and **Surface Acoustic Wave** Touchscreen options
- DVI, Composite and BNC video input options

Touchscreen Models

LBT-08420TEAR	5-Wire Resistive RS232 Touch O/F Monitor
LBT-08420TEARU	5-Wire Resistive USB Touch O/F Monitor
LBT-08420TEAS	SAW RS232 Touch O/F Monitor
LBT-08420TEASU	SAW USB Touch O/F Monitor

Specifications

LED Panel

TFT Active Matrix Color
8.4 inch diagonal viewable
SVGA 800 x 600 resolution (maximum)
0.213 x 0.213 mm pixel pitch
16.2 million color display
450 nit brightness (typical, 80-90% with touchscreen)
80% luminance uniformity (minimum)
600:1 contrast ratio (typical at 25°C)
30 ms response time (typical)
±80°L/R, 80°U, 60°D
50,000 hours MTBF (minimum at 25°C)

Video Interface

VGA compatible analog RGB
24-54 kHz horizontal scan
50-90 Hz vertical refresh
OSD (On Screen Display) keys

Mechanical and Environment

Operation Temperature: -30~85°C [-20~185°F]
Storage Temperature: -30~85°C [-20~185°F]
Humidity: 80% maximum
244 x 179 x 41.5 mm [9.61 x 7.05 x 1.63 inch]
1 kg [2.2 lbs]

Power Management

VESA DPMS Standard
6W normal mode
+2W for Touch Overlay
12V/2A, 24W, Universal Input Adapter

Technical Data

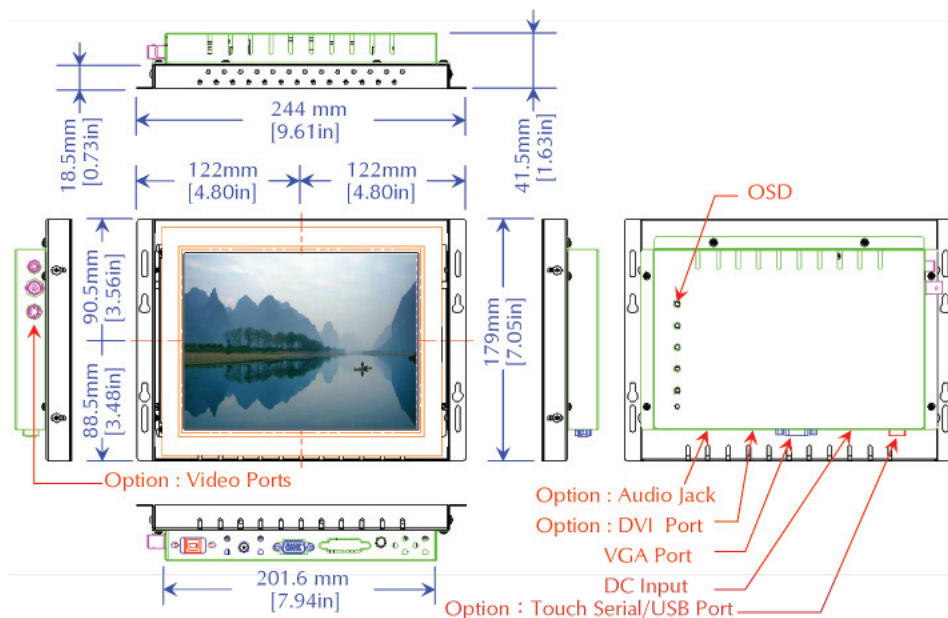

Caltron Industries Inc
Display Solutions Provider Since 1997

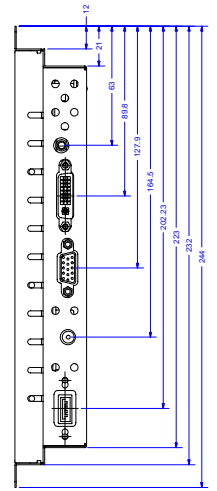
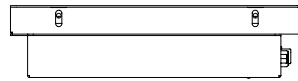
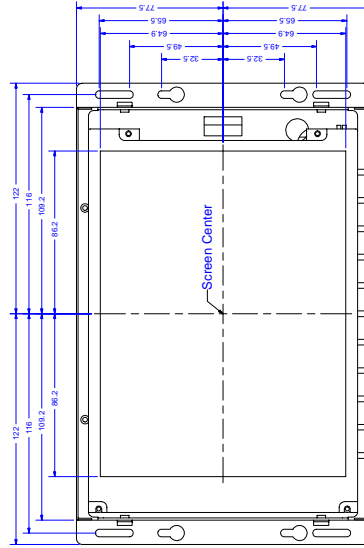
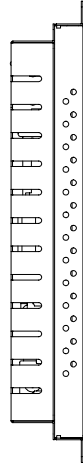
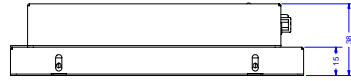
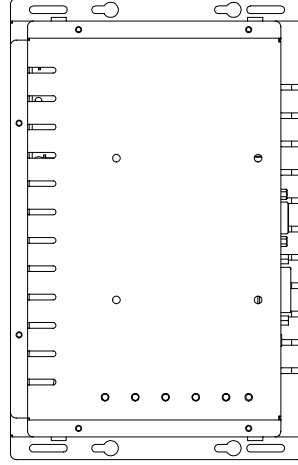
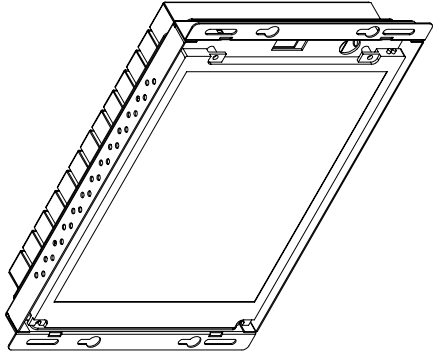

REVISED	DATE	BY	DESCRIPTION
1	08/07/14		
COMPANY: Caltron Industrial, Inc. TITLE: 8.4" Open Frame DATE: 08/07/14 DRAWN BY: E CHECKED BY: E PART NO: FBT-08420 SHEET 1 OF 1			